



MULTISCALE

1080p Scaler Box

Operation Manual

TABLE OF CONTENTS

1. Introduction	1
2. Features	1
3. Package Contents	1
4. Operation Controls and Functions	2
4.1 Front Panel.....	2
4.2 Rear Panel.....	2
4.3 OSD Operation.....	4
4.4 Remote Control.....	5
5. MULTISCALE RS-232 Remote Control Protocol	6
6. Specifications	9
6.1 General Specification.....	9
6.2 Support Resolution.....	9
7. Connection and Installation	10

1. Introduction

SPATZ's Multiscale Scaler Box is designed to upscale digital/analog video signal from Composite, S-Video, PC, Component (HD) and HDMI input sources, to digital HDMI output of wide-range HDTV and PC resolutions, up to 1080p and WUXGA (1920 x 1200.) Besides video upscaling, the scaler box also converts digital/analog audio signal to digital format, then output either through HDMI combining with the video, or Coaxial S/PDIF separately. SPATZ Multiscale has a comprehensive OSD menu that allows user to select a variety of output resolutions and adjust for best picture quality.

2. Features

1. HDMI 1.2, HDCP 1.1 and DVI 1.0 compliant.
2. Scales any PC (VGA ~ WUXGA) /HD (480i ~ 1080p) resolutions to/from another PC/HD resolutions.
3. Automatically detect the factory setting of the connected display and output the corresponding resolution and refresh rate, when the NATIVE output is selected.
4. Supports 50/60Hz frame rate conversion.
5. Supports 3-D motion video adaptive, 3-D de-interlacing, and 3:2 / 2:2 pull-down detection and recovery.
6. Provides output picture adjustment on contrast, brightness, hue, saturation, sharpness, RGB (color tone) level, and aspect ratio size.
7. Supports high resolution input/output:
PC: VGA, SVGA, XGA, SXGA, UXGA, WXGA, WSXGA, WUXGA
HDTV: 480i, 576i, 480p, 576p, 720p, 1080i, and 1080p
8. Supports digital and analog audio input and output.
9. Automatic input selection for HDMI and VGA, VGA has priority. Unit defaults to HDMI if not VGA signal is connected.
10. **SPATZ AUTOSCALE**
Since 01.11.2011 we offer a new firmware with the unit that incorporates our **AUTO SCALE**. This function allows automatic scaling of any input signal maintaining original aspect ratio by scaling the input format to the selected output format using either full display height or full display width. No more image distortion with egg shaped circles. As an example the unit will accept a XGA input image (4:3) and display it centered on a 1080p (16:9) output image with correct aspect ratio. The scaler will scale 768 lines to 1080p and increase the horizontal pixels by the same ratio and filling left and right side with black bars to complete the 1920 pixels.

3. Package Contents

1. SPATZ Multiscale Scaler Box
2. D-Sub (15pin) Cable
3. 3XRCA Cable (Composite Video + L/R Audio)
4. Remote Controller
5. 5VDC Power Supply Adaptor
6. Operation Manual

4. Operation Controls and Functions

4.1 Front Panel

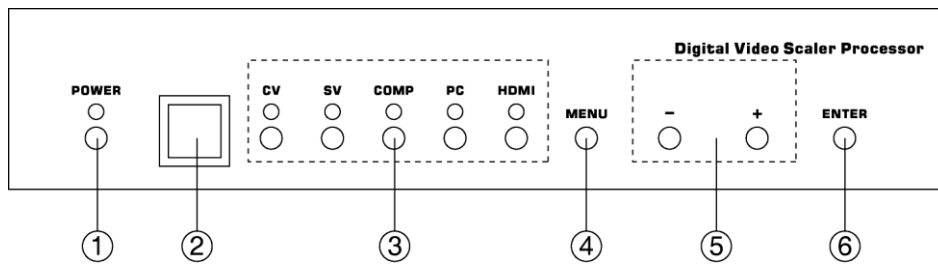

1. POWER Button and LED Indicator:

Press the button to turn ON/OFF the power of the unit. The LED will illuminate when the power is turned on.

2. IR remote control sensor.

3. Input Selection Buttons and LED Indicators:

Press each of the buttons (CV/SV/COMP/PC/HDMI) to select the desired input source. The LED will illuminate when the corresponding input is selected.

4. MENU Button:

Press the MENU button to bring up OSD operation menu (see section "4.3 OSD Operation" for reference.)

5. +/- Buttons:

- On the first tier of OSD menu, use + and - buttons to move up/down the highlight item for selection.
- Once the desired option is selected, use + and - buttons to toggle between setting values.

6. ENTER Button:

In OSD menu, use the ENTER button to confirm the selection.

4.2. Rear Panel

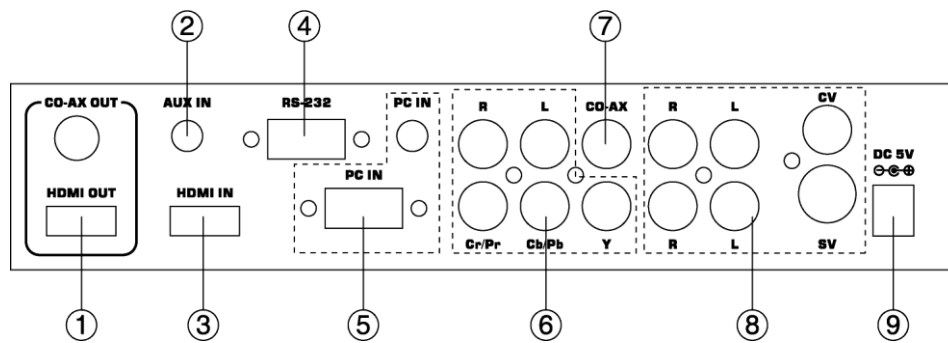

1. HDMI OUT and CO-AX OUT:

Connect the HDMI OUT port to the HDMI input port of your display such as HDTV. Connect the CO-AX OUT port to the Coaxial (S/PDIF) input port of your amplifier for separate digital audio output.

2. AUX IN Input:

When the video signal input through the HDMI IN port is from a DVI source such as a PC, use the AUX IN port to input the audio signal.

3. HDMI IN Input:

Connect the HDMI IN port to the HDMI output port of your source equipment such as DVD player or Set-Top-Box. Or, use HDMI to DVI cable to connect to the DVI output of your PC.

4. RS-232: Remote Control Port, for AMX or Crestron control systems

5. PC IN for Video and Audio Input:

Connect the PC IN D-Sub (15-pin) port to the D-Sub output port of your PC. And, connect the PC IN 3.5mm phone jack to the audio output port of your PC.

6. Y Pb/Cb Pr/Cr Video and L/R Audio Input:

Connect the Y Pb/Cb Pr/Cr (Component) 3 RCA input ports to the Component output port of your video source equipment such as DVD player or Set-Top-Box. And, connect the L/R audio input ports to the audio output port of your audio source equipment.

7. CO-AX Input:

The CO-AX port provides the digital audio input support, and can be used to combine with each video input signals from CV/SV/COMP/PC/HDMI ports. Once connected, please use the Audio Source Selection in the OSD menu to select between Coaxial (S/PDIF) or other audio source (see section "4.3 OSD Operation" for reference.)

8. Composite Video / S-Video and L/R Audio Input:

Connect the Composite or S-Video input port to the Composite or S-Video output port of your video source equipment such as DVD player or Set-Top-Box. And, connect the L/R audio input ports to the audio output port of your audio source equipment.

9. Power:

Plug the 5VDC power supply into the unit and connect the adaptor to AC wall outlet.

4.3. OSD Operation

1st Tier Option	2nd Tier Option	Adjustment
VIDEO	- PICTURE MODE	USER / STANDARD / VIVID / MOVIE
- CONTRAST		0 ~ 100 of Contrast Level
- BRIGHTNESS		0 ~ 100 of Brightness Level
- HUE		0 ~ 100 of Hue Level
- SATURATION		0 ~ 100 of Saturation Level
- SHARPNESS		0 ~ 100 of Sharpness Level
- SCALE		OVERSCAN / UNDERSCAN / LETTERBOX / PANSCAN / FULL
- NR		LOW / MIDDLE / HIGH / OFF
- EXIT		Back to the 1st Tier
COLOR	- COLOR TONE	USER / NORMAL / WARM / COOL
- RED		0 ~ 100 of Red Color Level
- GREEN		0 ~ 100 of Green Color Level
- BLUE		0 ~ 100 of Blue Color Level
- EXIT		Back to the 1st Tier
OUTPUT	-	NATIVE / VGA / SVGA / XGA / SXGA / UXGA / 480i / 480p / 720p@60Hz / 1080i@30Hz / 1080p@60Hz / 576i / 576p / 720p@50Hz / 1080i@25Hz / 1080p@50Hz / WXGA / WSXGA / WUXGA
OSD	- HPOSITION	0 ~ 100 of OSD Horizontal Position
	- VPOSITION	0 ~ 100 of OSD Vertical Position
	- TIMER	0 ~ 100 of OSD Show Time (sec.)
	- TRANSP	0 ~ 100 of OSD Transparent Level
	- EXIT	Back to the 1st Tier
AUDIO	- SOURCE	HDMI / L/R / COAXIAL
- DELAY		OFF / 40MS / 110MS / 150 MS
- SOUND		ON / MUTE
- EXIT		Back to the 1st Tier
INFORMATION	-	SOURCE (Input interface) INPUT (Input Resolution) OUTPUT (Output Resolution) VERSION (Firmware Version)
EXIT	-	Close the OSD Menu

4.4. Remote Control

1. POWER:
Press the button once to power on the Multiscale
Press again
to enter standby mode.
2. INPUT:
Press the button repeatedly to toggle through
various input sources.
3. HD Input:
Press the button to directly select component input.
4. PC Input:
Press the button to directly select PC input.
5. HDMI/DVI Input:
Press the button to directly select DVI (or HDMI) input.
6. Output Resolution:
Press any one of the button to directly select output
resolution. For other output resolutions that are not covered
by these buttons please enter OSD Menu to select them.
7. MENU:
Press the button to bring up OSD main menu page.
8. Exit:
Press the button to exit from a sub menu or main menu.
9. Up/Down/Left/Right:
Press the Up/Down button to move the highlight bar to your desired parameter during the
OSD operation. Press the Left/Right button to increase/decrease the setting value of a
selected parameter.
10. OK (Enter):
Press the button to confirm your selection.
11. Reset:
Press the button to reset the unit's firmware setting to the factory default value.
12. Auto Adjust:
Press the button to optimize the position of the picture (picture centering) on the screen.

5. Specifications

5.1. General Specification

- * Frequency bandwidth: 1.65Gbps (single link)
- * Input Ports:
 - Composite x 1 / L/R x 1
 - S-Video x 1 / L/R x 1
 - Component (3 RCA) x 1 / L/R x 1
 - PC D-Sub (15-pin) x 1 / 3.5mm Phone Jack x 1
 - HDMI x 1 / 3.5mm Phone Jack x 1 (for DVI) Coaxial (S/PDIF) x 1
- * Output Ports: HDMI x 1
Coaxial (S/PDIF) x 1
- * 5V DC power supply
- Dimensions: 215(W) x 154(D) x 47(H)mm*
- Weight: 1K

Pin definition for serial cable

Multiscale			Remote Controller	
PIN	Definition		PI	Definition
1	NC		1	NC
2	TxD		2	Rx
3	RxD	→	3	Tx
4	NC		4	NC
5	GND	←	5	GND
6	NC		6	NC
7	NC		7	NC
8	NC		8	NC
9	NC		9	NC

RS-232 transmission format:

BaudRate: 19200 bps

Data Bit: 8 bits Parity: None

Stop Bit: 1 bit

Serial Commands:

Command Code	Response	Description
S POWER 0	> POWER OFF	POWER OFF
S POWER 1	> POWER ON	POWER ON
S SOURCE 0	> SOURCE CV	CV INPUT
S SOURCE 1	> SOURCE SV	SV INPUT
S SOURCE 2	> SOURCE COMP	COMP INPUT
S SOURCE 3	> SOURCE PC	PC INPUT
S SOURCE 4	> SOURCE HDMI	HDMI INPUT
S OUTPUT 0	> OUTPUT NATIVE	NATIVE RESOLUTION OUTPUT
S OUTPUT 1	> OUTPUT VGA	VGA RESOLUTION OUTPUT
S OUTPUT 2	> OUTPUT SVGA	SVGA RESOLUTION OUTPUT
S OUTPUT 3	> OUTPUT XGA	XGA RESOLUTION OUTPUT
S OUTPUT 4	> OUTPUT SXGA	SXGA RESOLUTION OUTPUT
S OUTPUT 5	> OUTPUT UXGA	UXGA RESOLUTION OUTPUT
S OUTPUT 6	> OUTPUT 480I	480I RESOLUTION OUTPUT
S OUTPUT 7	> OUTPUT 480P	480P RESOLUTION OUTPUT
S OUTPUT 8	> OUTPUT 720P	720P 60HZ RESOLUTION OUTPUT
S OUTPUT 9	> OUTPUT 1080I	1080I 60HZ RESOLUTION OUTPUT
S OUTPUT 10	> OUTPUT 1080P	1080P 60HZ RESOLUTION OUTPUT
S OUTPUT 11	> OUTPUT 576I	576I 60HZ RESOLUTION OUTPUT
S OUTPUT 12	> OUTPUT 576P	576P 60HZ RESOLUTION OUTPUT
S OUTPUT 13	> OUTPUT 720P	720P 50HZ RESOLUTION OUTPUT
S OUTPUT 14	> OUTPUT 1080I50	1080I 50HZ RESOLUTION OUTPUT
S OUTPUT 15	> OUTPUT 1080P50	1080P 50HZ RESOLUTION OUTPUT
S OUTPUT 16	> OUTPUT WXGA	WXGA RESOLUTION OUTPUT
S OUTPUT 17	> OUTPUT WSXGA	WSXGA RESOLUTION OUTPUT
S OUTPUT 18	> OUTPUT WUXGA	WUXGA RESOLUTION OUTPUT
S SIZE 0	> SIZE FULL	SCALER FULL OUTPUT
S SIZE 1	> SIZE OVERSCAN	SCALER OVERSCAN OUTPUT
S SIZE 2	> SIZE UNDERSCAN	SCALER UNDERSCAN OUTPUT
S SIZE 3	> SIZE LETTERBOX	SCALER LETTERBOX OUTPUT
S SIZE 4	> SIZE PANSCAN	SCALER PANSCAN OUTPUT
S SIZE 5	SIZE FOLLOW INPUT	OUTPUT IMAGE FOLLOWS INPUT
S PICTUREMODE 0~3	> PICTUREMODE STANDARD~USER	0:STANDARD; 1:MOVIE; 2:VIVID; 3:USER, PICTURE MODE OUTPUT

S CONTRAST 0~100	> CONTRAST 0~100	CONTRAST 0~100 ADJUST [Default:50]
S BRIGHTNESS 0~100	> BRIGHTNESS 0~100	BRIGHTNESS 0~100 ADJUST [Default:45]
S HUE 0~100	> HUE 0~100	HUE 0~100 ADJUST [Default:50]
S SATURATION 0~100	> SATURATION 0~100	SATURATION 0~100 ADJUST [Default:60]
S SHARPNESS 0~100	> SHARPNESS 0~100	SHARPNESS 0~100 ADJUST [Default:32]
S NR 0~3	> NR OFF~HIGH	0:OFF; 1:LOW; 2:MIDDLE; 3:HIGH, NR CONTROL
S PCHPOSITION 0~100	> PCHPOSITION 0~100	H POSITION 0~100 ADJUST
S PCVPOSITION 0~100	> PCVPOSITION 0~100	V POSITION 0~100 ADJUST
S PCCLOCK 0~100	> PCCLOCK 0~100	PC MODE COLCK 0~100 ADJUST
S PCPHASE 0~63	> PCPHASE 0~63	PC MODE PHASE 0~63 ADJUST
S COLORTEMP 0~3	> COLORTEMP NORMAL~USER	0:NORMAL; 1:WARM; 2:COOL; 3:USER, COLOR TEMP SETTING
S RED 0~100	> RED 0~100	COLOR TEMP "RED" ADJUST [Default:47]
S GREEN 0~100	> GREEN 0~100	COLOR TEMP "GREEN" ADJUST [Default:47]
S BLUE 0~100	> BLUE 0~100	COLOR TEMP "BLUE" ADJUST [Default:47]
S OSDHPOSITION 0~100	> OSDHPOSITION 0~100	OSD H POSITION 0~100 ADJUST [Default:50]
S OSDVPOSITION 0~100	> OSDVPOSITION 0~100	OSD V POSITION 0~100 ADJUST [Default:50]
S OSDTIMEOUT 0~100	> OSDTIMEOUT 0~100	OSD TIMEOUT 0~100 SETTING [Default:10]
S OSDBACKGROUND 0~8	> OSDBACKGROUND 0~8	OSD OSDBACKGROUND 0~8 ADJUST [Default:5]
S AUDIOMUTE 0~1	> AUDIOMUTE OFF~ON	0:OFF; 1:ON, AUDIO MUTE CONTROL
S AUDIODELAY 0~3	> AUDIODELAY OFF~150MS	0:OFF; 1:40MS; 2:110MS; 3:150MS, AUDIO DELAY SETTING
S RESET 1	> RESET ON	RESET ACTION

(B) Status Commands: (Retrieve Status)

Command Code	Response	Description
R POWER	> POWER ON	SHOW POWER STATUS
R SOURCE	> SOURCE CV~HDMI	SHOW SOURCE STATUS
R OUTPUT	> OUTPUT NATIVE~WUXGA	SHOW OUTPUT STATUS
R SIZE	> SIZE FULL~PANSKAN	SHOW SIZE STATUS
R PICTUREMODE	> PICTUREMODE STANDARD~USER	SHOW PICTURE MODE STATUS
R CONTRAST	> CONTRAST 0~100	SHOW CONTRAST STATUS
R HDCPKEY	> HDCPKEY ON/OFF	Show HDCPKEY status
S HDCPKEY 0	> HDCPKEY OFF	input HDCP off
S HDCPKEY 1	> HDCPKEY ON	input HDCP on
R BRIGHTNESS	> BRIGHTNESS 0~100	SHOW BRIGHTNESS STATUS
R HUE	> HUE 0~100	SHOW HUE STATUS
R SATURATION	> SATURATION 0~100	SHOW SATURATION STATUS
R SHARPNESS	> SHARPNESS 0~100	SHOW SHARPNESS STATUS
R NR	> NR OFF~HIGH	SHOW NR STATUS
R PCHPOSITION	> PCHPOSITION 0~100	SHOW PC H-POSITION STATUS
R PCVPOSITION	> PCVPOSITION 0~100	SHOW PC V-POSITION STATUS
R PCCLOCK	> PCCLOCK 0~100	SHOW PC COLOK STATUS
R PCPHASE	> PCPHASE 0~63	SHOW PC PHASE STATUS
R COLORTEMP	> COLORTEMP NORMAL~USER	SHOW COLOR TEMP STATUS
R RED	> RED 0~100	SHOW COLOR TEMP RED STATUS
R GREEN	> GREEN 0~100	SHOW COLOR TEMP GREEN STATUS
R BLUE	> BLUE 0~100	SHOW COLOR TEMP BLUE STATUS
R OSDHPOSITION	> OSDHPOSITION 0~100	SHOW OSD H-POSITION STATUS
R OSDVPOSITION	> OSDVPOSITION 0~100	SHOW OSD V-POSITION STATUS
R OSDTIMEOUT	> OSDTIMEOUT 0~100	SHOW OSD TIMEOUT STATUS
R OSDBACKGROUND	> OSDBACKGROUND 0~8	SHOW OSD BACKGROUND STATUS
R AUDIOMUTE	> AUDIOMUTE OFF~ON	SHOW AUDIO MUTE STATUS
R AUDIODELAY	> AUDIODELAY OFF~150MS	SHOW AUDIO DELAY STATUS

5.2. Supported Resolutions

INPUT	
PC	VGA@(60/72/75/85Hz), SVGA@(56/60/72/75/85Hz), XGA@(60/70/75/85Hz), SXGA@(60/75/85Hz), XGA@60Hz, WXGA@60Hz, WSXGA@60Hz, WUXGA@60Hz
TV	480i, 480p, 576i, 576p, 720p@(50/60Hz), 1080i@(25/30Hz), 1080p@(50/60Hz)
OUTPUT	
PC	VGA@(60/72/75/85Hz), SVGA@(56/60/72/75/85Hz), XGA@(60/70/75/85Hz), SXGA@(60/75/85Hz), UXGA@60Hz, WXGA@60Hz, WSXGA@60Hz, WUXGA@60Hz
TV	480i, 480p, 576i, 576p, 720p@(50/60Hz), 1080i@(25/30z), 1080p@(50/60Hz)